

HELMET-STYLE TRAILER LOCK

KBIF-94A/105A

ALARM
120dB

STAINLESS
STEEL



Features

1. Innovative and highly protective helmet design with built-in 120dB anti-theft security alarm
2. Removable ball to fit on/ off towing trailers and other range of hitches
3. Made by premium 304 stainless steel for strength and durability
4. Applies with superior corrosion and stain resistant treatment
5. IP67 water-resistant
6. Includes 3 keys, enabling share-use between family members and friends

Specifications

Ball size	46mm
Maximum locking width	89.2mm/105mm
Maximum locking height	55.6/ 62mm
Product net weight	1644g/ 1900g
Material	Stainless steel
Battery type	CR2 lithium (typical lifespan: 8 months)
Color available	Brushed metal

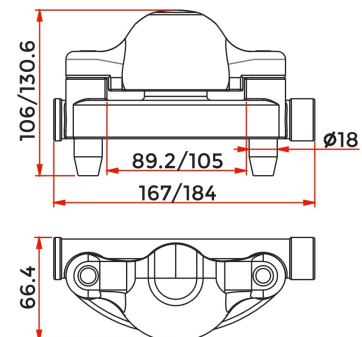

Fit Coupler Size

